

CATALOG NUMBER	FIG. NO.	NOMINAL CABLE RANGE	BAIL SIZE	"A" LENGTH	"B" WIDTH	"C" DIAMETER
WSS1	1	6	#2	3.81 [97]	4.63 [118]	.25 [6]
WSS2	1	5, 4, 2				
WSS2X						
WSM1	1	1, 1/0, 2/0				
WSM2	1	2/0, 3/0				
WSM3	1	3/0, 4/0				
WSM4	2					
WSM5	1	266.8	#2	-----	-----	-----
WSM6	2					
WSM7	2	350	1/0	4.35 [110]	4.70 [119]	.324 [8]
WSL1	2	336.4	2/0	-----	-----	-----
WSL2	2					
WSL3	2					
WSL4	2					
WSL5	2					
WSL6	2					
WSL7	2	397.5 - 477	1/0	-----	-----	-----
WSL8	2		2/0	-----	-----	-----
WSL9	2		4/0	-----	-----	-----
WSL10	3	556.5	1/0	-----	-----	-----
WSL11	3		2/0	-----	-----	-----
WSL12	3		4/0	-----	-----	-----
WSL13	3	636	4/0	-----	-----	-----
		795	2/0	-----	-----	-----
			4/0	-----	-----	-----

NOTES:

1. DIMENSIONS IN BRACKETS [] ARE IN MILLIMETERS ROUNDED OFF TO THE NEAREST MILLIMETER, UNLESS OTHERWISE SPECIFIED AND ARE FOR REFERENCE ONLY.

REV	DATE	DESCRIPTION	ECO	BY	C'H.K.
C	07/20/2015	DRAWING UPDATED AS PER MARKUP	40986	SV	MB

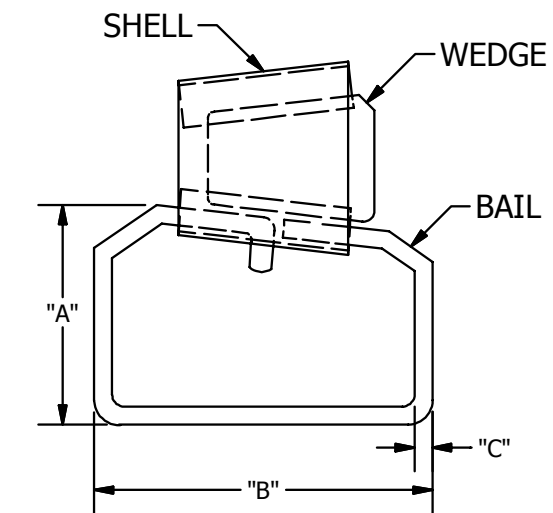

FIG. 1

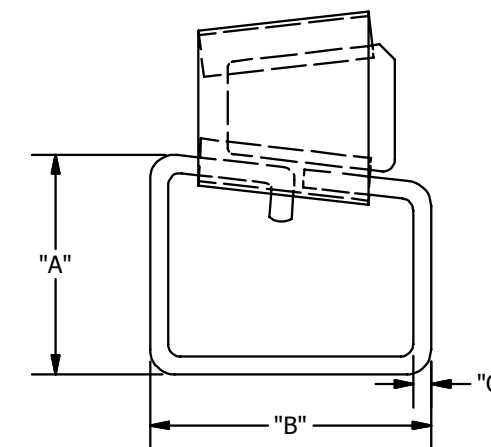

FIG. 2

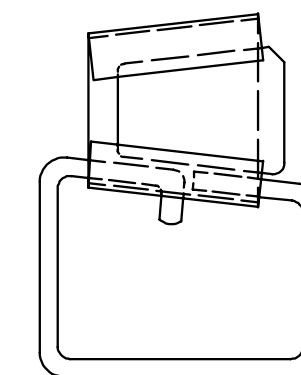

FIG. 3

TO ORDER BURNDY PRODUCTS CALL		STIRRUP™ ASSEMBLY	
UNITED STATES		ITEM NO: N/A	
1-800-346-4175 (LONDONDERRY, NH)		CAT. NO: WS--/BPT (TABLE)	
CANADA:		DRAWN BY: V KAMAL 06-11-2012	
1-800-361-6975 (QUEBEC)		CHECKER: S PUNNEN 06-25-2012	
1-800-387-6487 (ALL OTHER PROVINCES)		DSN APRVL: J PAULO 10-28-2014	
FOR PRODUCT INFO: http://www.burndy.com		MFG APRVL: G NISHIMURA 11-04-2014	
		QA APRVL: --	
		MKT APRVL: J HALL 10-25-2014	
		PROD FAM: --	
		DRAWING NO	
		50002276	
		REV	
		C	
		SHEET 1 OF 1	